



PROSIZER® 2612V

Portable FRAP Processing | Superior Toughness | Unmatched Screen Capacity

HIGH FREQUENCY SCREEN



AGGREGATE AND
MINING GROUP

The ProSizer® 2612V is the ideal solution for processing milled RAP for asphalt producers. This closed circuit mobile plant incorporates a double deck PEP Vari-Vibe® high frequency screen with a KPI-JCI horizontal shaft impactor (HSI). Hydraulic screen angle adjustment and rotary screen tensioning system allows producers to make the changes necessary to meet different RAP applications with ease. This unit has central grease points and easy-to-reach engine controls for routine service. The quick set-up time of less than 15 minutes allows the producer to move around to multiple job sites and process FRAP back to its original size. All of this combines to allow the producer to increase RAP usage while adding flexibility and improved control in mix designs.

PROSIZER[®] 2612V

12 cu. yds

Heaped capacity hopper with 6'X13' top opening.

173 HP

Tier III John Deere water cooled diesel engine to power all plant functions.

6'x12'

PEP Vari-Vibe[®] 2612V double deck high frequency screen.

Up to 200 TPH

Screening plant can process up to 200 TPH or more of feed material.

PERFORMANCE

- P1 Horizontal Shaft Impactor**
This new impactor from KPI-JCI provides increased capacity, wear life and reliability.

DURABILITY

- D1 Stealth Tappet Design**
Redesign of this component makes the vibrators more durable.

SAFETY

- S1 Dust Cover**
The vinyl dust cover provides dust control and cleaner air in the work area.

EASE-OF-USE

- E1 Increased Ground Clearance**
Transport and maneuver the system easily.
- E2 Central Grease Points**
Makes routine services easy.

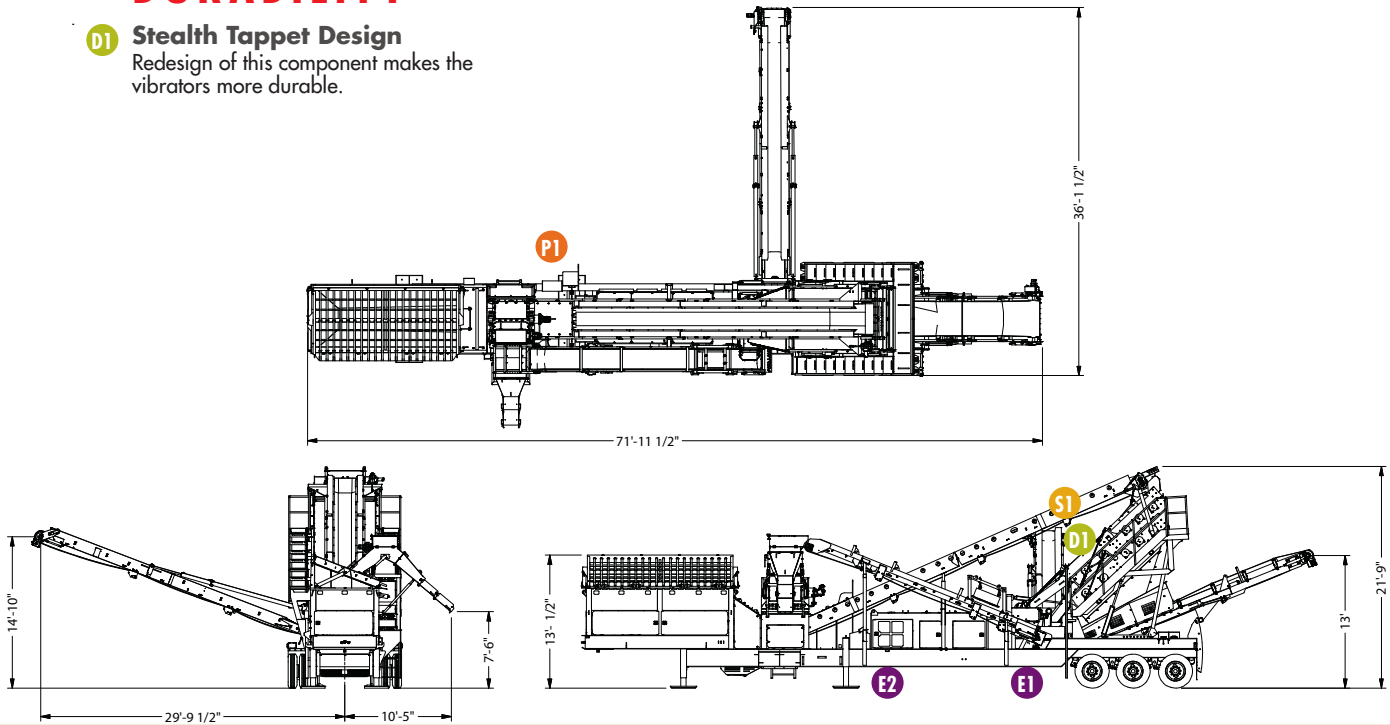

STEALTH TAPPETS

Redesigned variable speed hydraulic vibrator tappets produces less sticking of material and better wear. 10 tappets are mounted below the screens for directly induced vibrating action.



HIGH FREQUENCY SCREEN

A double deck PEP Vari-Vibe[®] high frequency screen with hydraulic screen angle adjustment and rotary screen tensioning system can meet the different RAP application demands with ease.



HORIZONTAL SHAFT IMPACTOR

The KPI-JCI 3136 Horizontal Shaft Impactor (HSI) is capable of processing 75 TPH of oversized material. Three different blow bar materials are available for a variety of applications.

www.kpijci.com

GUARANTEED BUY BACK

Prosizer will make your guaranteed specs or we will buy it back from you!

SERVICE MADE EASY

Because we're dedicated to keeping you up and running, we've provided two resources for quality O.E.M. parts and 24/7 service. Astec Mobile Screens parts and service are available from your local dealer and/or representative at 800.545.2125

Find the dealer or representative nearest you at www.kpijci.com.

Because Astec Mobile Screens may use in its catalog & literature, field photographs of its products which may have been modified by the owners, products furnished by Astec Mobile Screens may not necessarily be as illustrated therein. Also continuous design progress makes it necessary that specifications be subject to change without notice. All sales of the products of Astec Mobile Screens are subject to the provisions of its standard warranty. Astec Mobile Screens does not warrant or represent that its products meet any federal, state, or local statutes, codes, ordinances, rules, standards or other regulations, including OSHA and MSHAGATOR, covering safety pollution, electrical, wiring, etc. Compliance with these statutes and regulations is the responsibility of the user and will be dependent upon the area and the use to which the product is put by the user. In some photographs, guards may have been removed for illustrative purposes only. This equipment should not be operated without all guards attached in their normal position. Placement of guards and other safety equipment is often dependent upon the area and the use to which the product is put. A safety study should be made by the user of the application, and, if required, additional guards, warning signs and other safety devices should be installed by the user, wherever appropriate before operating the products.

NOTE: SPECIFICATIONS ARE SUBJECT TO CHANGE WITHOUT NOTICE

REV. 1/6/2011